

ENGINEERING	CRIMP SPECIFICATION	SPEC. No.:SCCD002A
DEPT.	For CD52T01*BPP TERMINAL	PAGE: 1 / 1

1. Crimp height and width of crimped core should be set as required. (crimped height and width of wire barrel)
2. Crimp width of crimped sheath shall be adjusted according to the final out side diameter and the kind of electric wire, to the extent that sheathed wire won't be easily taken off from contact nor too much crimped. (crimped width of insulation barrel)

Core wire shall be Dim. L mm out

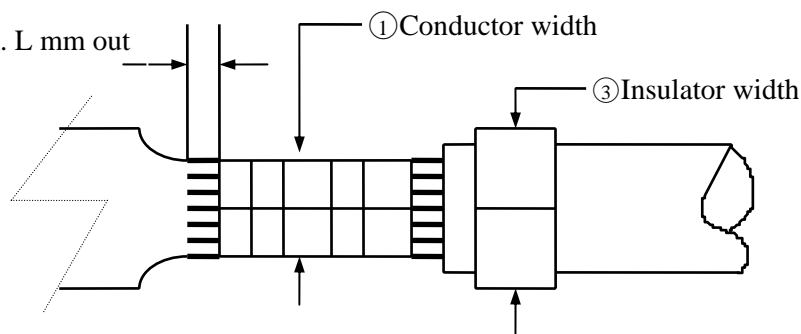

Naked part of sheathed wire must be located in the vicinity of center

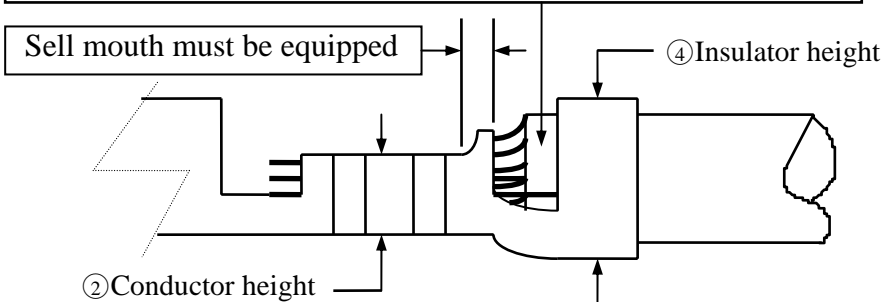

Subject : UL 1007 or equivalent type electric wire

AWG #	Conductor mm ²	Insulator Diameter	Applicator	Core crimp length	Dim. L
#24 - #28	0.227-0.089	1.2-1.45mm	A01CD52T01P	1.7-2.0mm	0.2-0.4mm

Wire Gage (AWG #)	Conductor Crimp Area		Insulator Crimp Area		Terminal Tensile Strength
	Width (1)	Height (2)	Width (3)	Height (4)	
#24	1.50-1.60	0.75-0.85	1.80-1.90	---	3.0 Kgf
#26		0.72-0.82		---	2.0 Kgf
#28		0.70-0.80		---	1.3 Kgf

DATE	REVISIONS	SPEC BY:	Jim 8/21 06'
		CHKD BY:	David 8/21 06'
		APPR BY:	Alex 8/21 06'

